

CAIRNCROSS

PROJECT EXPERIENCE

# Rail Depots & Infrastructure



# Cairn Cross are a multi-disciplined design and build specialist main contractor for rail depots and bespoke projects.

Our promise is complete client satisfaction, every project, every time.

## Get in touch

[www.cairncross.uk.com](http://www.cairncross.uk.com)

Info: [info@cairncross.uk.com](mailto:info@cairncross.uk.com)

Careers: [careers@cairncross.uk.com](mailto:careers@cairncross.uk.com)

Cairn Cross,  
1 Cadman Court,  
Morley, Leeds,  
LS27 0RX



0113 284 2415

# Services we provide

As a multi-discipline Design and Build specialist, we deliver a wide range of services across all sectors for public and private sectors.



## Rail Infrastructure

From modifications to complete new depot facilities, including wheel lathes, carriage washes, bogie drop facilities, fuelling, CET and AdBlue.



## Rail Depots

Our complete design and build capabilities allow Cairn Cross to undertake all works as the main contractor, from pre-construction to complete depot construction completion.

### Full services & capabilities include:

- ▶ Mechanical & Electrical
- ▶ Product Innovation
- ▶ Fabrication
- ▶ Pollution Control
- ▶ Water
- ▶ Design & Build

### Milestones

5+

Carriage Wash Installations

9

Wheel Lathe Installations

15+

Bridges

20+

CET Installations

50+

Rail Depots

50+

Nationwide team

## Previous clients



## Accreditations and awards



# We're a design & build main contractor

For over a decade, Cairn Cross has developed our specialist, dedicated in-house design team to ensure we can complete a project from the initial pen sketch to the delivery of the finished build. This commitment to having one source of contact for your whole project ensures a more seamless and transparent approach, which enhances efficiency.



## Our Process

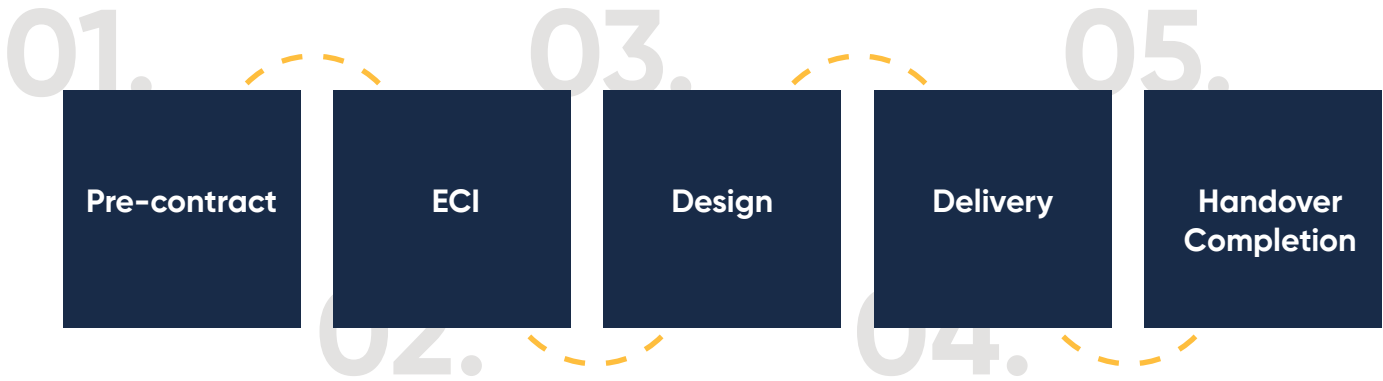

## Design services



## Our values

Our promise is complete client satisfaction, every project, every time.

Our core values focus on the people, planet and our performance of works. Everyone strives together to serve employees, clients, and the broader community to the best of our abilities.



Our Work Safe Live Safe strategy for the Health and Safety of our workforce is driven by our desire to create a positive safety culture and ensuring all levels of staff and supply chain are incorporated into our efforts. This strategy looks to go beyond the traditional health and safety role of preventing harm and promote a vigilant and proactive culture towards everyone's health and safety in the workplace.



## Community committed

We engage with our local working communities from school activities, university lectures and sustainable donations.

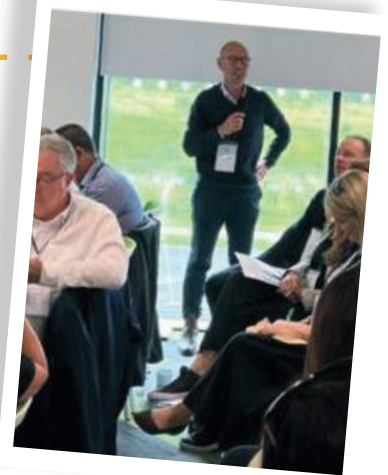

## We pledge to plant over 200 trees in 2024

Cairn Cross is committed to sustainability and practices to offset and lower our carbon footprint



## Depot Works

For over twenty-five years, Cairn Cross has worked exclusively within the rail industry, providing specialist, reliable outcomes and deliverables to our clients throughout the UK rail network.



## Design

Our in-house dedicated design team are experts in the rail network, providing a wide range of knowledge and experience to every project.

## Build

As main contractors, Cairn Cross has built everything from superstructures and buildings to p-ways, carriage washes, and pit drops.



## Exceptional Safety

Our site safety management goes above and beyond industry standards to ensure all works carried out is without harm to our workforce and supply chain.

# Peterborough Rail Maintenance Hub

A Design & Build project to construct a rail maintenance depot



Customer  
**GB Railfreight**

Value  
**£5,700,000**

Location  
**Peterborough**

## PROJECT OVERVIEW

- ▶ Design & Build
- ▶ Principal Contractor
- ▶ Mechanical & Electrical
- ▶ Portal Frame Building
- ▶ Tandem Wheel Lathe
- ▶ S & C Automated Points
- ▶ New Power Supply
- ▶ New P-Way Siding
- ▶ Swarf Conveyor
- ▶ Fume Extraction System
- ▶ Depot Protection System



## The Challenge

A design and build project for a new 95-metre superstructure shed with two roads, a gantry crane and jacking systems to provide maintenance facilities.

## The Solution

The state-of-art maintenance hub improves safety and reliability across GBRF's wagon fleet, using smart sensor technology to quickly analyse wagon conditions and identify faults much earlier quickly and accurately. The Hub, which is larger than six-Olympic swimming pools, was built on derelict land bringing new economic activity and around 20 permanent jobs to the local area.



## The Result

The new facility was completed and handed over to the client within 10 months of ground work commencing. Transport Secretary MP Mark Harper who opened the new maintenance facility said 'It's a fantastic achievement, built in 10 months, my ears did prick up a little bit when you said it was built on time and on budget, that's always very attractive'.

CECA Awards 2023  
**Project of the Year**  
**- Highly Commended -**

## Hull Botanic Gardens

Maintenance shed extension and new facilities



Customer  
**Northern Rail**

Value  
**£3,100,000**

Location  
**Hull**

### PROJECT OVERVIEW

- ▶ CET
- ▶ Drainage & Walkways
- ▶ Electrical & CCTV
- ▶ Fuelling & AdBlue
- ▶ Fume Extraction
- ▶ Jacking
- ▶ P-way
- ▶ Steelwork & Cladding
- ▶ Tanking



### The Challenge

Northern Rail required an extension to their existing maintenance depot and new roofing in order to increase servicing of their new rolling stock. The depot was to remain open and operational throughout the project.

### The Solution

A new steel super-structure canopy was constructed over the existing depot adding an additional road to the left of the depot. Along with associated civil ground works such as foundations, drainage and lightning, the Cairn Cross team installed CET, fuelling, stabling and AdBlue to the site.



### The Result

The new depot allows Northern Rail to provide maintenance and B exams to members of its Class 170 and Class 155 fleets.



## Oxley Train Depot Extension

Integrated solutions for eleven new car Pendolino train sets. We extended and raised the building, included an inspection pit and extended the existing track.



Customer  
**Alstom Traincare**

Value  
**£1,900,000**

Location  
**Oxley, Wolverhampton**

### PROJECT OVERVIEW

- ▶ Cable Installation
- ▶ Concrete Foundations, Bases and Walkways
- ▶ Electrical Installation
- ▶ Fabrication
- ▶ Maintenance Pit
- ▶ P-Way
- ▶ Steel Structural Building
- ▶ Track Crossings



### The Challenge

The roof of the existing building was raised to allow the building to remain watertight during the construction process. The beams, purlins and roof sheets were reused, providing a cost-saving to our client and reduced this projects carbon footprint.

### The Solution

Building around and eventually re-routing optic fibre cables controlling the main call centres and track sensitive communications, utilizing cradles and shrouds allowing the client to fit the diversion in with their works programme. Changing metal key clamp handrail for the non conductive GRP handrail.



### The Result

Working with the client ensured their maintenance regime was uninterrupted and allowed the project to be delivered on time to a demanding programme.



## Queens Road New Maintenance Depot

Design and build contract for the provision of a maintenance workshop and associated works.



Customer  
**Stagecoach Metrolink**

Value  
**£2,400,000**

Location  
**Queens Road, Manchester**

### PROJECT OVERVIEW

- ▶ AVIS
- ▶ Bogie Drops
- ▶ Cable Installation
- ▶ Carriage Wash
- ▶ Concrete Bases
- ▶ Depot Maintenance
- ▶ Design & Build
- ▶ Inspection Pit
- ▶ Steel Structures



### 1 The Challenge

As part of the Manchester Phase 1 and 2 Upgrade and Renewals Programme, Metrolink added a fleet of new trains onto the line. The existing depot needed upgrading to manage the 44 new vehicles. This project included the repair, upgrade and installation of new services.

### The Solution

The project works included the construction of an additional new shed with an inspection pit, 120 metres long. We removed the existing rail track before constructing the new cavity and building the enclosed new steel structure building. New CFA (Continuous flight auger) and driver platforms were installed along with an overhead monorail crane, depot protection system, compressed air system, oil distribution and a radiant heating system.



### 3 The Result

The project was completed within the proposed time frame, allowing Metrolink to issue out and sufficiently offer maintenance to their new fleet of vehicles.



## Oxley Depot Subsidence

Due to subsidence issues, Cairn Cross replaced 137m length of the Road 16 rail pit walls and associated works.



Customer  
**Alstom**

Value  
**£2,375,000**

Location  
**Oxley, Wolverhampton**

### PROJECT OVERVIEW

- ▶ Cable Installation
- ▶ Concrete Bases
- ▶ Depot Modifications
- ▶ Drainage
- ▶ Electrical Installation
- ▶ Lighting
- ▶ Maintenance Pits
- ▶ P-Way
- ▶ Floor Painting



### 1 The Challenge

Due to subsidence issues, approximately sixty metres of permanent way rail track and maintenance pit were closed due to safety concerns. Cairn Cross took the possession of the shed from the North East entrance through to the end of the new pit construction to excavate the pit and reinstate 137 metres of new rail tracks and maintenance pits in the depot.

### The Solution

Cairn Cross temporarily removed the interior access platforms to gain safe access to remove 137 metres of subsided track and pit. The rail was removed and stored for reuse, and the pit walls and walkways were excavated. Once demolished, new reinforced steel and formwork was lifted into place, and concrete poured and struck. Once the new pit walls, walkways and track was implemented, we carried out the lighting and associated works.

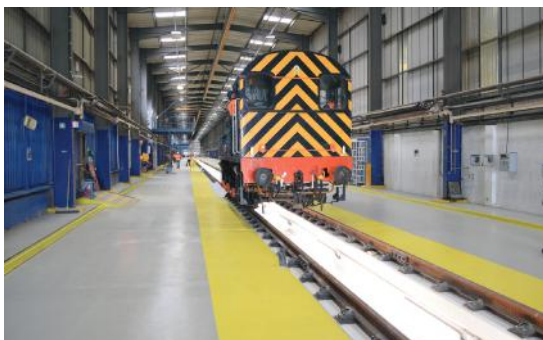

### 3 The Result

The new depot allows for the maximum efficiency of maintenance work to be carried out throughout the entire length of the shed. New safety stairwells and lighting within the pit improve the overall safety of the depot.

# WHEEL LATHES

For over a decade, Cairn Cross are the market leaders in the installation and maintenance of wheel lathes throughout the United Kingdom's national rail infrastructure.

[cairncross.uk.com/wheel-lathes](http://cairncross.uk.com/wheel-lathes)

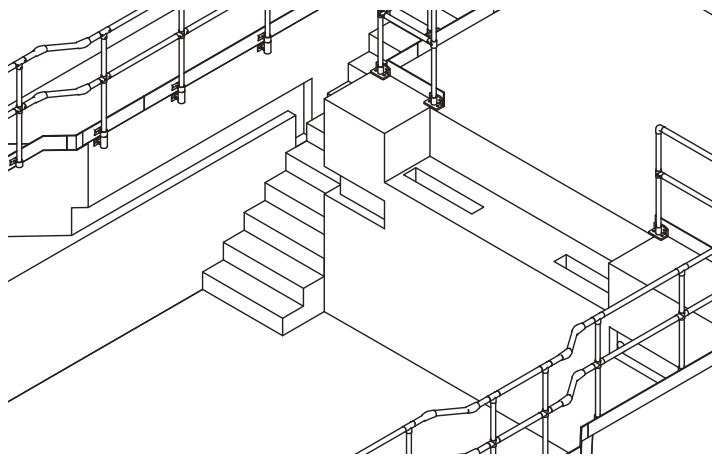

## Design

Our expertise and dedicated specialist in-house design team can lead as principal designers creating detailed visual plans to house any Wheel Lathe installations.

## Build

From removal to installation and pit form work, we have accrued over two decades of experience managing the upgrade works to wheel lathe depots.



## Specialists

For over ten years, Cairn Cross has worked as Principal Contractor and Principal Designer leading Design & Build Wheel Lathe projects for a wide array of clients. Our decade of experience means we can deliver diverse requirements easily.

## Central Rivers Wheel Lathe

A Design & Build project to supply a brand new tandem wheel lathe facility with new building and new p-way siding



Customer  
**Bombardier/Alstom Rail**

Value  
**£5,624,000**

Location  
**Burton-on-Trent**

### PROJECT OVERVIEW

- ▶ Design & Build
- ▶ Principal Contractor
- ▶ Mechanical & Electrical
- ▶ Portal Frame Building
- ▶ Tandem Wheel Lathe
- ▶ S & C Automated Points
- ▶ New Power Supply
- ▶ New P-Way Siding
- ▶ Swarf Conveyor
- ▶ Fume Extraction System
- ▶ Depot Protection System



### The Challenge

A brand new wheel lathe facility was required at the Central Rivers Depot in Burton-on-Trent to provide an enhanced facility for tyre-turning at the depot for the newly introduced fleet of Bombardier Flexity Swift vehicles in the network. The wheel lathe was to be housed within a new portal steel frame building, accessed via a new p-way siding, controlled by new automated points.

### The Solution

Existing bunded area cleared and new p-way siding constructed with vehicle crossing and track drainage. Dewatering system put in place to enable pit excavation and main foundation formation in challenging conditions. Tandem wheel lathe procured and installed. Portal steel frame building constructed with insulated cladding panels and skylights. Power supply routed from existing building. Fume extraction system installed. Swarf conveyor constructed with reinforced external slab for waste skip.



### The Result

Despite challenging ground conditions, a brand new wheel lathe facility was delivered, comprising a new p-way siding, a tandem wheel lathe and a new building with administration office, plant room and kitchen area. Bombardier/Alstom were provided with a modern and upgraded depot and associated works to facilitate their continued maintenance work.





## Neville Hill Wheel Lathe

Project to deliver the civil engineering work and foundations for the installation of the Network Rail owned Wheel Lathe.



Customer  
**RTMS**

Value  
**£285,000**

Location  
**Neville Hill, Leeds**

### PROJECT OVERVIEW

- ▶ Cable Installation
- ▶ Concrete Bases
- ▶ Depot Modifications
- ▶ Electrics
- ▶ Floor Painting
- ▶ Principal Contractor
- ▶ Principal Designer
- ▶ P-Way
- ▶ Wheel Lathe



### 1 The Challenge

This project was to provide the construction works associated with the installation of the Hegenscheidt Wheel Lathe at Neville Hill, Leeds. The work included undertaking the role of Principal Contractor and Principal Designer and providing a supervisory role for the Wheel Lathe provider to Site Acceptance Testing (SAT) (including training).

### The Solution

Work undertaken included the draining and safe disposal of operating fluids, disconnection and disassembly of electrical power supply and existing 106 Underfloor Wheel lathe ready for reuse later and removal from site. We constructed a new maintenance pit including stairs, safety handrails, paintwork and electrical works.



### 2 The Result

Following the supervision of the Wheel Lathe installation and maintaining full client compliance, the wheel lathe was successfully installed and operating within the project time frame.



### 3.



## Craigentiny Underfloor Wheel Lathe

Turnkey design and build contract to install a new single headed Hegenscheidt CNC wheel lathe.



Customer  
**Network Rail**

Value  
**£1,750,000**

Location  
**Craigentiny, Edinburgh**

### PROJECT OVERVIEW

- ▶ Cable Installation
- ▶ Concrete Bases
- ▶ Depot Modifications
- ▶ Electrics
- ▶ Floor Painting
- ▶ Principal Contractor
- ▶ Principal Designer
- ▶ P-Way
- ▶ Wheel Lathe



### 1. The Challenge

The scheme involved the removal of the old Lathe, demolition of the concrete foundations and significant re-modelling of the structure within the existing building.

The new Lathe pit is 8.3 metres long, 7 metres wide and 4 metres deep. A new section of the concrete floor was required within the building spanning 50 metres.

### 2. The Solution

The first stage of the project was the removal of the current wheel lathe, which would be used in a different depot facility. The existing pit was demolished and replaced with a new, more supportive concrete base pit. The new Hegenscheidt CNC wheel lathe was lowered into place by a Megalift system and finalised by associated mechanical and electrical works.



### 3. The Result

The scheme was handed back to the operator (East Coast) 6 weeks ahead of schedule.

# CET

We have completed significant rail projects as Principal Contractor installing Controlled Emission Toilet Systems (CET) nationwide. Cairn Cross has developed our own unique system, dramatically improving existing solutions.

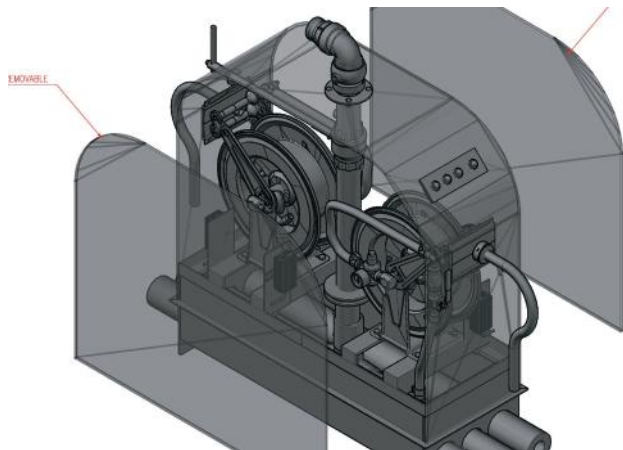
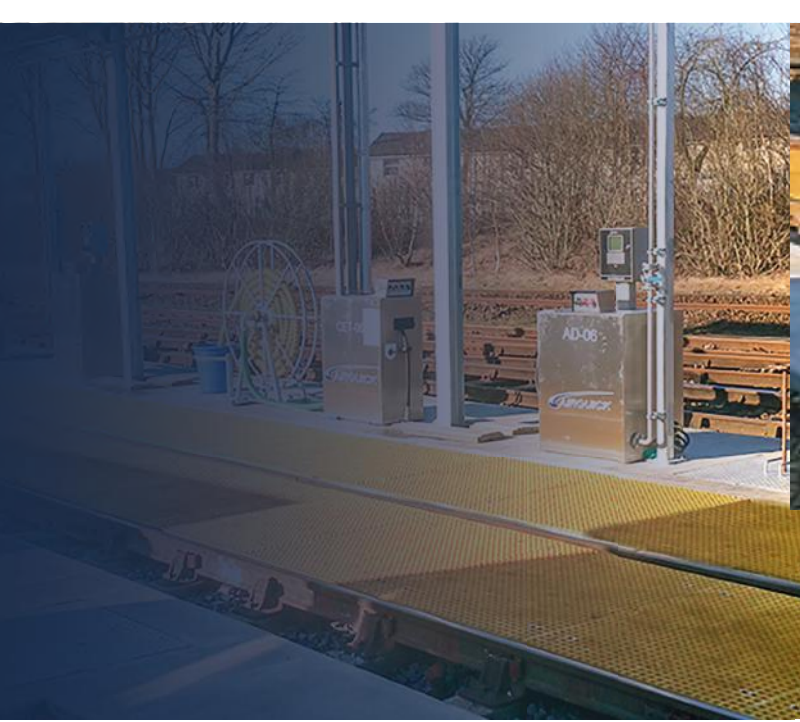

## Design

Cairn Cross combine expertise with innovation, offering a complete design solution for your CET provision in depots complete with TrackPan, Lighting and our own unique CET module.

## Build

Taking leadership throughout the design, build and delivery stage, Cairn Cross provides complete CET module installations to suit your depot needs.



## Inventor

Cairn Cross and Interquip Global Ltd have co-engineered a pioneering new CET system providing modern, efficient and reliable handling of effluent for the rail network.



## Newton Heath

Greater Anglia required upgrades to facilitate changes to the train fleet.



Customer  
**Northern Rail**

Value  
**£980,000**

Location  
**Manchester**

### PROJECT OVERVIEW

- ▶ AdBlue
- ▶ CET
- ▶ Design & Build
- ▶ Principal Contractor
- ▶ Plant Room
- ▶ Trackpan
- ▶ Fuelling
- ▶ GRP Walkways
- ▶ Tanking Points



### 1 The Challenge

Adblue provision and CET modules are required at Newton Heath depot to enable Adblue to incorporate into the fuelling operations on the new rolling stock fleet coming into the depot.

### The Solution

Cairn Cross installed a new depot canopy and apron housing a new fuelling point, six AdBlue points and one CET module with associated drainage, potable water storage tank and GRP walkways with overhead lighting to improve depot safety.

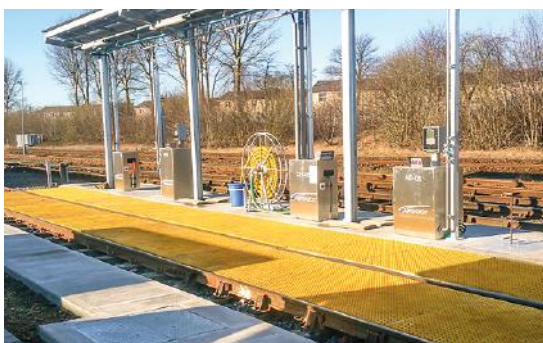

### The Result

The project's on-time completion allows Northern Rail to continue expanding and maintaining their fleet at the Newton Heath, Manchester depot.

# CET Upgrade & Installation

Design and build project for the provision of CET, fuelling points and lighting.



Customer  
**Alstom**

Value  
**£1,285,000**

Location  
**Longsight, Manchester**

## PROJECT OVERVIEW

- ▶ AdBlue
- ▶ CET
- ▶ Concrete Base & Walkways
- ▶ Design & Build
- ▶ Fuelling
- ▶ GRP Walkways & Crossings
- ▶ LED Lighting
- ▶ Pipework
- ▶ Principal Contractor



### 1 The Challenge

Install an additional three CET points and AdBlue facilities with associated pipework, footpaths, GRP crossings complete with new lighting solutions. The depot is on an embankment, meaning soft landscaping was required.

### 2 The Solution

Cairn cross removed the existing CET modules and their concretes bases and footpaths and replaced them with new troughs, pipework, concrete bases and updated modules. Cairn Cross replaced current lamppost heads with a twin spigot, 2 LED street lights and bollard lighting throughout the roads and a new distribution board. Overhead Lines (OLE) on Roads 9, 10 and 11 were removed as these are no longer required.



### 3 The Result

Delivered within a tight time frame, Longsight now has three updated roads with CET, fuelling, AdBlue and safety lighting installed throughout the new GRP and concrete footpaths.



## CET Upgrade & Installation

Design and build project to upgrade the Stockport Sidings CET system to enable CET operations on the new rolling stock fleet.



Customer  
**Northern Rail**

Value  
**£320,000**

Location  
**Stockport, Manchester**

### PROJECT OVERVIEW

- ▶ CET
- ▶ Concrete Base & Walkways
- ▶ Design & Build
- ▶ Drainage
- ▶ Electrical Supply
- ▶ GRP Walkways
- ▶ Pump Station
- ▶ Walking Routes
- ▶ Water Storage



### The Challenge

Northern Railway required the Controlled Emission Toilet (CET) pumps upgraded at Stockport Sidings to enable CET functionality to change the new rolling stock fleet stabling on the sidings. Excavation works and amendments to the train presentation were required.

### The Solution

Works included replacing a new reinforced concrete base with housing a water storage tank for the flushing operations' adjacent to the existing plant room.

Cairn Cross installed eight new manually operated CET service points to provide train tank effluent extraction for 2-car, 3-car units, 4-car & 5-car units. A newly constructed service pump station houses the pumps.



### The Result

The extension of new CET extraction pumps allowed increased management of the new fleet. Cairn Cross completed the area with new safe walking routes and electrical supply.

# Fuelling & AdBlue

Our rail experience in maintenance and train presentation ensures we provide complete turnkey projects as principal contractors from planning to delivery.

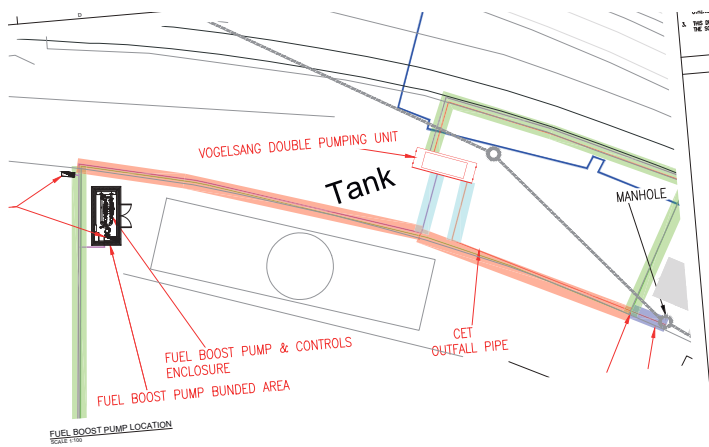

## Design

Offering over two decades of rail experience, our team of ground workers and designers can provide high-quality solutions and outcomes to the planning and execution of the project.

## Installation

Our dedicated specialist in-house mechanical and electrical team assist on all our projects to ensure that all elements and components are safely installed and working effectively.



## Trustworthy

Nearly 90% of the projects we carry out are within the rail network. We consistently deliver reliable resource and knowledge to the UK's rail sector.

## Edge Hill

Alstom Traincare UK required upgrades to the CET and Fuelling options on Liverpool Traincare centre Fuel Road for servicing TPE, 182 and 802 car sets.



Customer  
**Alstom Traincare UK**

Value  
**£750,000**

Location  
**Edge Hill, Liverpool**

### PROJECT OVERVIEW

- ▶ AdBlue
- ▶ Cable Installation
- ▶ CET
- ▶ Concrete Bases
- ▶ Concrete Footpaths
- ▶ Electrics
- ▶ Fuelling
- ▶ Lighting
- ▶ GRP Walkways



### The Challenge

Two new CET modules with four wholesome water cabinets with associated pumping were required. A new concrete foundation slab housed a new fuel delivery and two GRP AdBlue dispensers with a 10,000-litre tank.

### The Solution

Cairn Cross complimented the required infrastructure with the concrete aprons and installed 140 metres of GRP walkway with crossing points to gain safe access throughout the tracks. Cairn Cross included new safety access steps to gain access to the trains along the sidings.



### The Result

The extended and upgraded depot allows the maintenance work on the new car sets to be carried out on the Liverpool train line. The existing cleaners cabin was also upgraded with internal insulation, electricity, heating and new fabrication.

## Sheffield LMD Works, Yorkshire

Project to increase the servicing capacity at Sheffield Depot. The provision of Canopies, services, lighting and TrackPan.



Customer  
**Northern Rail**

Value  
**£700,000**

Location  
**Sheffield, Yorkshire**

### PROJECT OVERVIEW

- ▶ AdBlue
- ▶ Cable Installation
- ▶ CET
- ▶ Cladding
- ▶ Depot Modifications
- ▶ Steel Structure
- ▶ Tanking points
- ▶ Ventilation Units
- ▶ Walkways



### The Challenge

Due to Arriva Rail North Ltd increasing their servicing capacity at Sheffield Depot. The train fleet, including class 195's, class 170s and class 150s diesels in two and three-car configurations, is serviced at Sheffield depot. The existing arrangement needs to be enhanced to allow for the following servicing requirements: the project set out to design and construct a maintenance facility with fuelling, AdBlue and CET modules installed.

### The Solution

Removal of the existing spill protection and excavation to formation levels allowed the casting of 750mm reinforced ring beam to the sheds East and West. Cairn Cross settled a new steel frame with cladding rails complete with the TrackPan system and associated drainage and electrical works. Installation of an AdBlue tank with Armco Safety barriers completed the facility.



### The Result

The upgraded facility at Sheffield enables the maintenance allowance and growth of their vast fleet and services. The 35-metres of the new shed and facility extension will fulfil the increased demand.

## Bedford GTR

Cairn Cross carried out CET and train presentation as part of the phase 2 Jowett and Carriage Sidings project at Bedford.



Customer  
**GTR**

Value  
**£2,600,000**

Location  
**Bedford, Midlands**

### PROJECT OVERVIEW

- ▶ Access Gantries
- ▶ AdBlue
- ▶ CET
- ▶ Concrete Footpaths
- ▶ Design and Build
- ▶ GRP Steps & Walkways
- ▶ LED Lighting
- ▶ Principal Contractor
- ▶ Tanking



### The Challenge

As part of the 'Bedford Cauldwell Phase 2 scheme, Cairn Cross set out to deliver CET, Cleaners Cabinets, tanking services, access gantries, concrete walks, acoustic fencing, shed pit covering complete with signage and bollard lighting through the depot.

### The Solution

Cairn Cross installed 21 GRP gantries across multiple rail roads. New concrete walkways were formed in-situ and completed with LED bollard lighting and associated painting. Holdfast crossings were installed at the 12 car and 8 car end positions to allow manual cab end cleaning. The shed pit floor was covered with GRP plates.



### The Result

Delivered within the proposed time frame, the new facilities at the depot allow enhanced maintenance to the new fleet of train increasing traffic whilst maintaining high levels of safety to the site.

# Carriage Wash & AVIS

Over the last 25 years, Cairn Cross has designed, installed and maintained several bespoke train depot AVIS and complete carriage wash units.

[caircross.uk.com/carriage-wash-experience](http://caircross.uk.com/carriage-wash-experience)

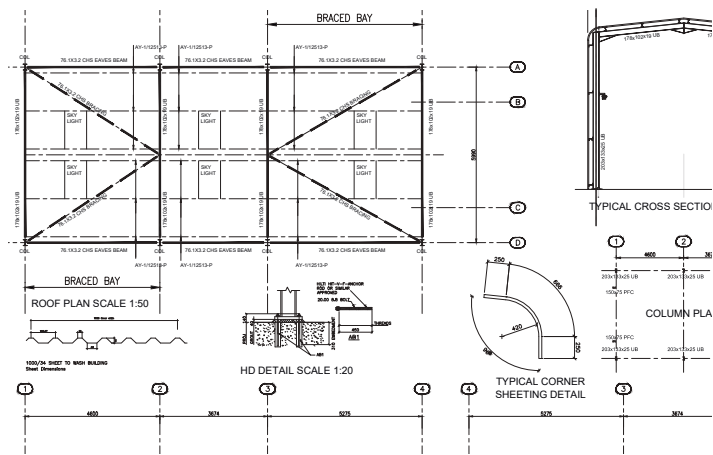

## Design

Working as Principal Designer, we have experience designing bespoke buildings and structures for carriage washes and AVIS units.

## Build

Our WSLS initiative ensures that all carriage washes are built and fabricated to the highest level of safety to maintain depot operations.



## Sustainable

Our TrackPan pollution containment solution ensures that no by-product or contaminated waste leaks into the surrounding natural environment.

## Train Wash Systems in Perth

Train Wash Systems Facility was constructed along with associated electrical and waterworks in Perth, Scotland.



Customer  
**Network Rail**

Value  
**£540,000**

Location  
**Perth, Scotland**

### PROJECT OVERVIEW

- ▶ Cable Installation
- ▶ Carriage Wash
- ▶ Cladding
- ▶ Design & Build
- ▶ Electrical Installation
- ▶ Fabrication
- ▶ Pollution Control
- ▶ Principal Contractor
- ▶ Trackpans



### The Challenge

The existing carriage wash at Perth Station needed replacing. The project was to install a new wash facility and remove the existing wash facility. The old carriage wash remained in use throughout the project to ensure that First Scot Rail could carry on with normal operations.

### The Solution

Cairn Cross installed: new drainage, foundations and a steel framed structure to house the washing equipment with automatic doors to provide cold weather protection. There was also a water storage tank and a plant room housing the detergent and pumping equipment.



### The Result

A new designated plant room housed all of the latest equipment, including a GRP water tank, detergent tanks, pumps and washing facilities. The finished building was the first of its kind in Scotland, offering suitable frost protection properties as given the harsh conditions and providing ease of maintenance and an extended life. The GRP track pans were also the first-ever installation of this type designed by Cairn Cross.



## Portobello Sidings Carriage Wash

Installation of CET modules and Carriage Wash facility.



Customer  
**East Coast Mainline**

Value  
**£400,000**

Location  
**Craigentenny, Edinburgh**

### PROJECT OVERVIEW

- ▶ Cable Installation
- ▶ Carriage Wash
- ▶ CET
- ▶ Concrete Walkways
- ▶ Drainage
- ▶ Electrics
- ▶ LED Lighting
- ▶ Trenches
- ▶ Water



### The Challenge

East Coast Mainline required a new carriage wash structure and CET modules to be installed along the depot roads. This would require water, electrical and safety works to be carried out while keeping the depot operational.

### The Solution

The works include supplying water, pipework and electrical facilities to a pumping station through new trenches. New concrete footpaths with LED bollards were formed and installed along three roads.



### The Result

Delivered within a tight deadline, the carriage wash and CET modules now offer East Coast Mainline with more maintenance facilities to manage their growing fleet of rolling stock.

## Carriage Wash Installation at Holyhead

Delivery of a new carriage wash shed and facilities to wash trains on the sidings.



Customer  
**Network Rail**

Value  
**£1,600,000**

Location  
**Holyhead, Isle of Anglesey**

### PROJECT OVERVIEW

- ▶ Cable Installation
- ▶ Carriage Wash
- ▶ CET
- ▶ Concrete Walkways
- ▶ Design & Build
- ▶ Drainage
- ▶ Electrics
- ▶ Principal Contractor
- ▶ Water



### The Challenge

Due to the increase in rail traffic, the client required a new steel carriage wash built on the railway's sidetrack. Network Rail required an additional maintenance road and shed facility to maintain the West Coast Mainline fleet. The new proposed shed houses a full-length 120 metres inspection pit.

### The Solution

The project required excavation works of the site, installing new reinforced tank foundations, galvanised steel frame erected, and purlins on the roof and sides with cladding. Further works included installing drainage and waste solutions, electrical works, and the carriage wash system.



### The Result

The project was delivered within time and was awarded the Star Lite Award for Site Safety.

Our TrackPan product innovation ensures pollution control by containing and preventing the leaching of contaminants such as diesel, gasoline, chemicals, oils, contaminated water, effluent or any other liquid polluting the surrounding environment.

Cairn Cross are a collaborative, progressive and innovative multi-disciplined engineering company that are shaping future infrastructure. We design and deliver significant infrastructure projects across the UK as main contractor and with in-house design capabilities.

**CAIRNCROSS**

1 Cadman Court, Morley, Leeds, LS27 0RX  
0113 284 2415 ▶ [info@cairncross.uk.com](mailto:info@cairncross.uk.com) ▶ [www.cairncross.uk.com](http://www.cairncross.uk.com)

Cairn Cross Civil Engineering Limited. Registered in England and Wales 03110217 ▶ VAT No566419417

